

DROP HAMMER

Introduction: Testing the response of solid, liquid or pasty substances to impact, friction and thermal stimuli is required in various standards like EEC, Official Journal of the European Communities as well as UN Recommendations on the Transport of Dangerous Goods, 13.4.2 Test 3(a)(ii) BAM Fallhammer.

The **Drop Hammer** is used to determine the sensitivity to impact of solid and pasty materials in accordance to the B.A.M. Method. The drop hammer also meets the requirements of above mentioned regulations.

It consists essentially of a cast steel block with cast-on base (400x400x50 mm) ①+②, a round anvil (100 Ø x70 mm) ③, a column fixed at the steel block, guide bars which are hardened and smoothed and the drop weight with retaining and releasing device. The

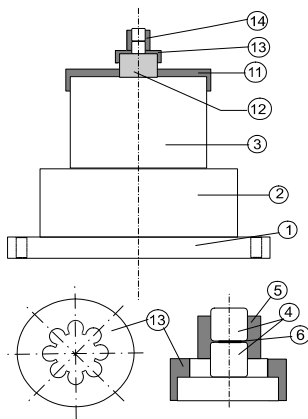

heavy iron block is essential to adsorb the shock waves caused by the falling weight. Both guide bars are attached to the column by means of three brackets. The column also carries a toothed rack to arrest the rebounding drop weight.

A self releasing stopper at the drop weight engages in the rack and avoids the falling back of the weight. An adjustable metre rule allows an exact measurement of the drop height, which can be 1 m in maximum.

Installation: The drop hammer should to be fixed on a massive concrete block of 70 x 70 x 60 cm in such a manner that the rails are absolutely perpendicular.

Procedure: The sample to be investigated is placed in the plunger assembly (14), consisting of two steel rollers, (height: 10 mm; diameter: $10_{-0,005}^{-0,003}$ mm; hardness: HRc 58..65; polished surfaces $r_a=0.08 \mu\text{m}$)④, a hollow steel collar



(Ø16 mm; height: 13 mm; polished bore of $10_{+0,010}^{+0,005}$) ⑤ and a centring ring (13) for fixation. The assembly is placed onto a small anvil 26x26mm (12).

Standard Accessories:

- | | |
|---------------------|--------------------------|
| 1 set steel rollers | 1 set steel collars |
| 1 pc centring ring | 1 ea. weight 1, 5, 10 Kg |
| 1 pc small anvil | 1 pc centring plate |
| 4 pcs spoons | |

Optional Accessories:

In order to protect the operator against any possible splintering, a protection case, made of wood, is highly recommended as well as a suction device, removing hazardous explosion gases.

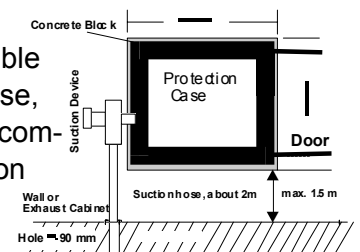

Protection cases (part no. 782-1015) and suction devices (part no 782-1059) are available as an option.